

Cymap 2012 - Readme File (July 2011)

This document contains late breaking information regarding your copy of Cymap. You should read this document before proceeding further. If you have web access, please view the support pages at <http://www.cymap.com> for further information. New databases and support related issues (plus frequently asked questions) regarding this release of the software are available from the web site.

New Features

Wiring - Multi Supply Scenarios

Multiple Supply Systems in Cymap Wiring

In previous versions of Cymap Wiring, only one supply point could be defined in each project file (*.CYW). Although two transformers could be specified as your supply point they were effectively only a single point of supply. In this release of Wiring it is possible to model systems that are completely independent of each other in the same project file. It is also possible to interlink these systems using Bus Coupled Switches.

Once the systems are drawn you can carry out fault analysis of Symmetrical Three Phase, Single Phase Short Circuits and Earth Faults in your interconnected systems. Full modelling with load flow analysis etc is not carried out but only calculated on a system by system basis with the combined fault of the operational transformers considered. This version will allow you to model larger systems found in Industrial and High Rise buildings with Multiple 11kV supplies and to carry out "what if" scenarios with Bus Couplers.

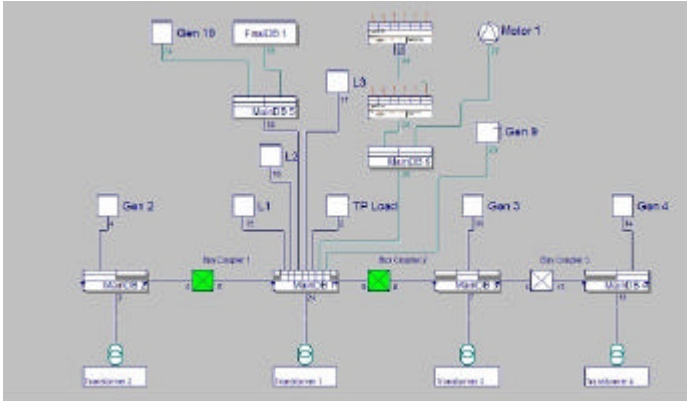

New Objects: This Version of Wiring introduces some new Objects that you will be required to use in order to be able to model parallel systems in Wiring.



Supply Transformer: You need to use this object to place a Supply Transformer onto the Network drawing. You will be prompted to enter details of its size & type etc when placing a new supply. At present there is a restriction on the number of supply points you can add to a project. This is currently set at 6 distribution points per project.

Bus Coupled Board:

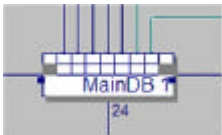

This is very similar to a normal main distribution board in previous versions of Wiring. However, it also has the ability to interconnect to another system. This is done by adding a cable (click inside the lower left or right hand half of the board). You will be prompted to see if you want to add a Bus-Coupling Way. You can then route a cable (or Busbar) to a bus-coupler (switch). This object always has a 'greyed out' way at each end of the board reserved for use by buscoupled ways and always draws with a connector at each end of the board.

Bus Coupler



This new object is required in order to join one system to another system. It also stores information in the project file relating to its current status e.g. whether the switch is open or closed. This means the current status of all bus couplers will be preserved when opening & saving project files. When opening & closing bus couplers, their status can be easily confirmed e.g. it is closed when it is filled in green and open when filled in white). The status of all bus couplers is analysed before main calculations are carried out to ensure only those systems that are currently in parallel with the selected system are evaluated.

Turning Transformers on/off:

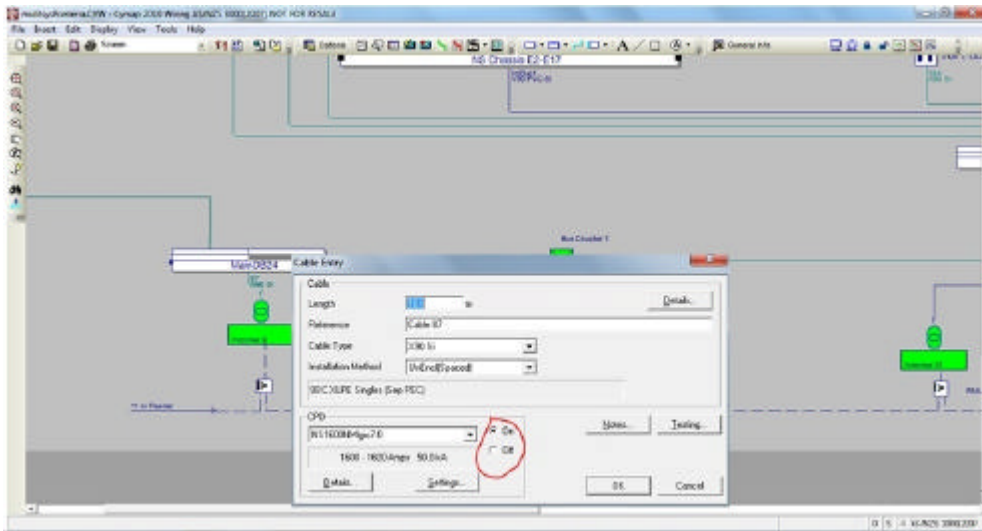

Editing Transformer Sizes and HV Protection settings for new Transformers

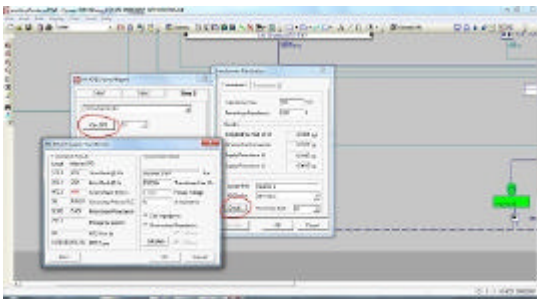

See screen shot above. It's now possible to model many supply conditions, e.g. feeding all systems from a single transformer or all transformers on and in parallel etc. Once you have placed more than one supply point on the Network drawing it is essential that at least one transformer is 'Active' or switched on. It's obvious from the network drawing what the current status of any Transformer is by looking at its colour. A solid filled in 'green' transformer indicates the transformer is on and active. To turn any transformer on or off simply double click the LV supply cable at the transformer and toggle its status to on /off. This, in conjunction with the bus ties (or bus coupler switches), allows an almost infinite number of supply arrangements to be modelled.

Resolving the Impedances for Parallel Systems:

Assuming we have N interconnected systems of supply, where each system comprises a transformer supply and transformers are essentially equally rated we wish to calculate system impedances for the sake of symmetrical short circuit fault, Single Phase and Earth fault calculations at one system, say x, where 1 greater than x which is greater than N. The calculations need to cater for multiple systems connected in parallel by means of bus couplers as shown in the diagram below.

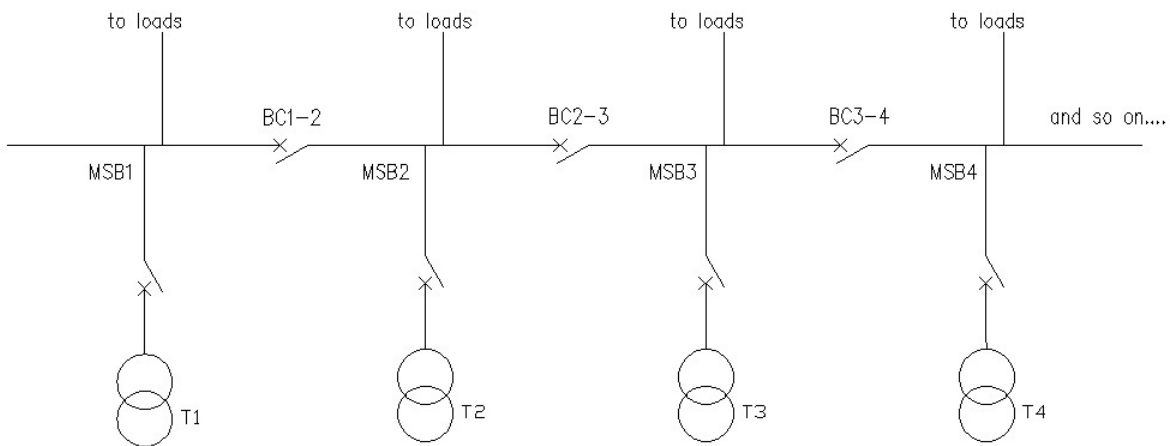

Therefore for switchboard level calculations the network can be simplified comprising the complex impedances as shown below.

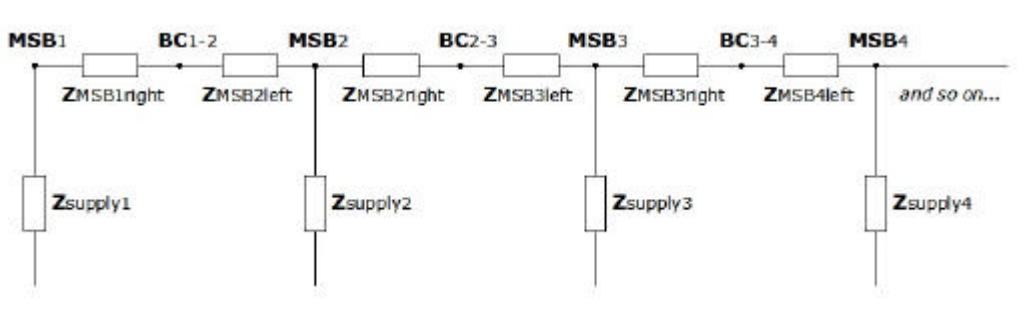

In order to calculate the impedances and fault levels at one system, the network can be further simplified as follows.

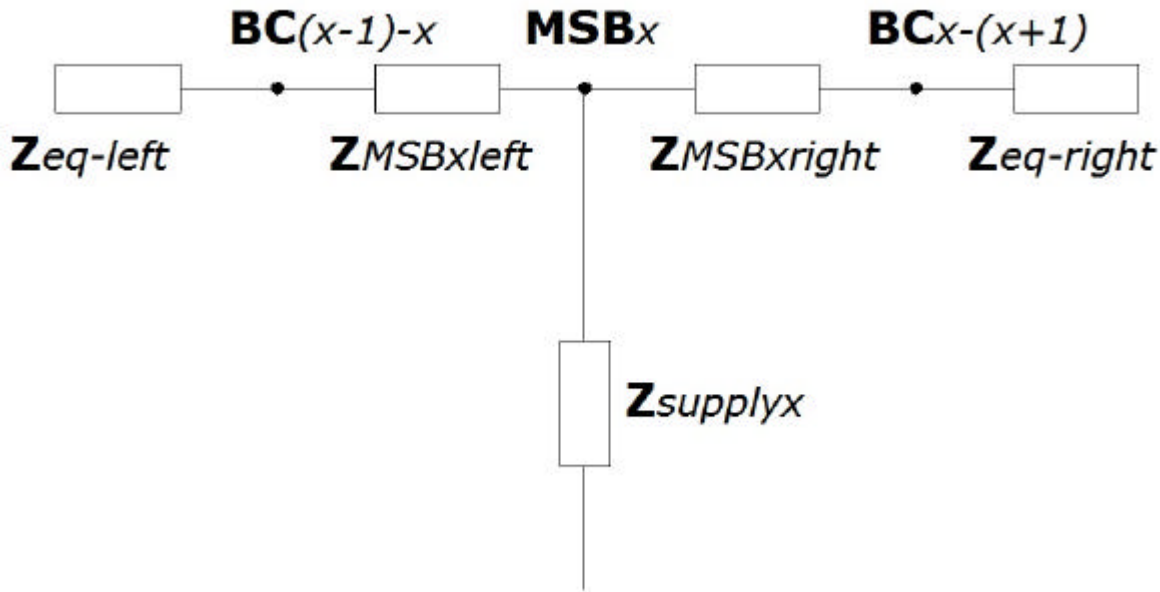

$Z_{eq-left}$ and $Z_{eq-right}$ are determined in an iterative manner using simple ladder network analysis methods until we end up with a Left -Right and Supply Impedance to the Current main switchboard & its associated supply system.

New Calculation Sequence:

Results for any system can be evaluated, by simply starting a calculation in the normal manner (from the display menu choose to calculate main or calculate all). Note results can only be obtained for one system at a time. However, the impedances of any connected systems will be taken into account for short circuit (Symmetrical three phase, Single phase & Earth Fault conditions). The sequence is now as follows (assuming more than one system has been entered into the current project).

- 1) The User starts a calculation. The system will ask the user to identify the supply point for the current system to be calculated.
- 2) An analysis is done to determine which Bus Couplers are closed and hence which systems need to be calculated, as systems on the opposite side of any open bus couplers will not be evaluated. Only systems connected to the currently selected system via a closed bus coupler will be considered in the calculations.
- 3) Each parallel system will be calculated in turn as an independent system in order to size cables on each system and evaluate cable sizes & impedances for the independent systems.
- 4) Each bus coupler during the calculation sequences in step 3 has the impedance back to each supply point to the left and the right of itself stored. This will be used later in the calculation sequence.
- 5) Now the currently selected system is re-calculated and a Ladder network fault analysis is carried out to evaluate the parallel short circuit & earth fault conditions. The fault level checks are re-evaluated upstream and downstream of the point of common coupling between systems, i.e. the main bus coupled board for the current system. Note, on this last pass all cable sizes are temporarily fixed and errors are simply reported for the closed bus coupler condition.
- 6) As projects with multiple systems can be large and the calculation loops are now called sequentially and iteratively, it may take a few minutes for the calculation loops to fully analyse the whole network down to final circuit and parallel networks.

Limitations of the Calculation:

- 1) Only one system at a time can be calculated and have results displayed for it.
- 2) Transformer Percentage Per Unit impedances are assumed to be identical so that paralleled systems share loads equally in accordance with their frame or rated sizes. A new error message will be shown if an attempt is made to parallel Transformers with unequal per unit percentage impedances.
- 3) Transformer Secondary Voltages are again assumed to be identical. The Secondary LV voltage is defined for a whole project and each transformer will be assumed to have the same secondary voltage output.
- 4) As mentioned in item 2, transformers are assumed to be identical and no load flow analysis is done for parallel systems. Each transformer is assumed to supply load current to all of the loads on its own system. Presently checks are made for each system to determine if the each supply transformer is overloaded independently.
- 5) As Load flow for Parallel Systems is not evaluated, Volt drop results along branches should be correct. However volt-drops along bus-coupled bus-bars at main switchboard level are not modelled and hence may not be valid for the parallel case. However, with couplers 'open' this will give worst case volt-drop levels and allow users to fix cable/bus bar sizes before closing bus-couplers.

6) Earth Fault. The parallel fault calc will only consider parallel impedances of systems that are seen when bus-couplers are closed. However, in practice the earthing system in a switch room that is fed by multiple transformers will have a common earthing arrangement. Hence the parallel paths will be present even if the bus coupler is open. However, when calculating Zs values the worst case figures will be when bus couplers are all open leading to no parallel path figures. Best case scenarios in terms of Zs values will be achieved by closing all bus couplers. It is important to remember that the ZS figure will only calculate parallel paths through closed bus couplers.

Multi System Supply Design Considerations

The program is designed, to calculate cable sizes and perform all calculations based on each individual single system which form part of an integrated supply transformer configuration, where groups of transformers are set up to run under normal operating conditions. This allows the engineer to consider "what if" scenarios based on transformers being coupled together or for other alternate supply arrangements.

When calculating a particular system you will be invited to select the system to be calculated by selecting its supply point. This supply point uses the fault levels generated from the supply transformer plus any others connected on line via bus couplers. This will result in only the cable sizes being shown for the particular system calculated but the generated fault calculated from the multi supply condition. Each system has to be calculated separately and the program has been designed to clear and/or make the engineer aware of any faults on a single system by system basis.

The program can be used to analyse the effects changes to the supply conditions have on each separate system, so the engineer can make a decision to make sure the cables and breakers used are suitable for a range of supply conditions that could be encountered based on design supply switching arrangements. The program will behave slightly differently under multi supply conditions in terms of auto sizing of CPCs for example. The program will alert the engineer to the problem and it's up to the engineer in this case to fix the CPC size so any faults can be cleared under a variety of supply scenarios to satisfy various "what if" scenarios. In this case don't expect a "separate" CPC to be sized for you as it would with a single entry system. It's better from a design perspective to allow the engineer to make the conscious decision by fixing a CPC size that satisfies all supply conditions as opposed the program calculating this automatically.

When calculating cable sizes, only the cables associated with the supply point the engineer selects will be shown. For example, for a twin transformer supply the engineer will have to calculate twice in order to view the cables results, once for "system1" and once for "system2". Each set of calculated results can be printed out each time with the supply reference appearing on the requisite printout.

ARC Flash Protection Additions: Wiring 2012

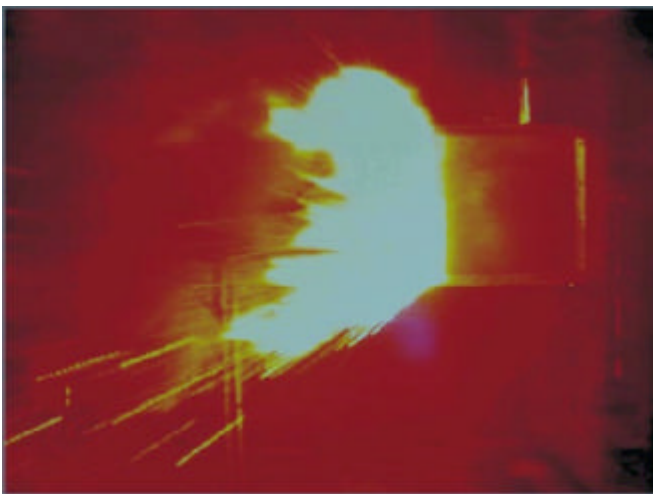

In some switchboards there can be very high fault levels present especially where there are multiple transformers feeding onto bus bars with bus couplers etc. This can lead to very high fault level currents and a risk of high Arc flash hazards (burns to operatives, molten metal etc). Where testing or working on live equipment needs to be carried out this presents a potential hazard to the workforce. The Electricity at Work Act in the UK has enforced rules around personnel and contractors that may be required to operate Motor Control Centres, lock off switchgear or test live equipment as part of their routine work. The EAW requires that suitable Personal Protective Equipment (PPE) is used, and that 'insulated' equipment may be required. There is nothing specific in the current version of the IEE Wiring regulations that specify what the danger or exposure levels to Arc Flash may be. In order to provide a safe working environment for employees and contractors working on these types of location the following information needs to be available:

An accurate Single Line Diagram (of the type produced by the Wiring Program) with accurate fault levels, based on correctly setting up the Single line diagram.

Transformer Sizes, Fault levels and % Impedance. Again this is taken care of by the software when creating Single line diagrams.

Accurate cable sizes and cable lengths, which can also be modelled in the software to produce accurate fault levels at any point in the Network.

Accurate modelling of your Circuit protection, so accurate disconnection times to clear potential faults are known. Using Cymap this is again easily achieved using Cymap Wiring and the Cymap Circuit Protection module.

Cymap Wiring now makes use of the National Fire Protection Agency (NFPA 70) standard. Other similar related standards are the IEEE 1584 to assess the potential Arc Flash levels. These standards are widely used in other countries like the USA, New Zealand, Australia etc. They are based on simple physics and provide essential information on protecting personnel from injury or death!

Wiring can now calculate the two most important values:

Arc Fault Boundary distance: (Db)

e.g. the distance you need to be from live equipment in order to sustain injuries less than second degree burns, e.g. 1.2 calories/cm²

or the distance in mm of a person from an arc source for a "just curable" burn (FLASH PROTECTION BOUNDARY - skin temperature remains less than 80 degrees Celsius)

Arc Fault Flash Levels :

The calories/cm² level at each point in the network, dependant on the fault level present and the disconnection time of the local circuit protective device. The calculations are based on tests in a cubic box (500mm on each side, opened on one end), 208v up to 600V systems with an electrode gap of 32 mm, and for available bolted short-circuit currents of between 16 to 50kA

These can be viewed alongside the fault levels on the single line diagram:

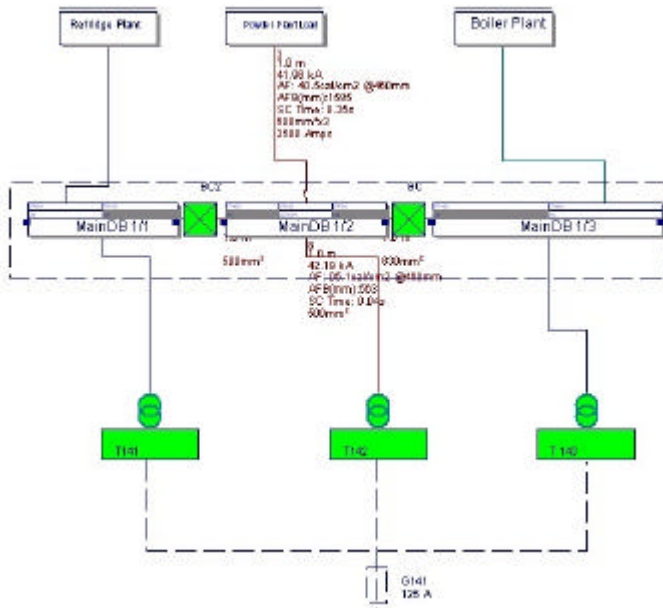

To enable this new feature simply go to the Display option Dialog

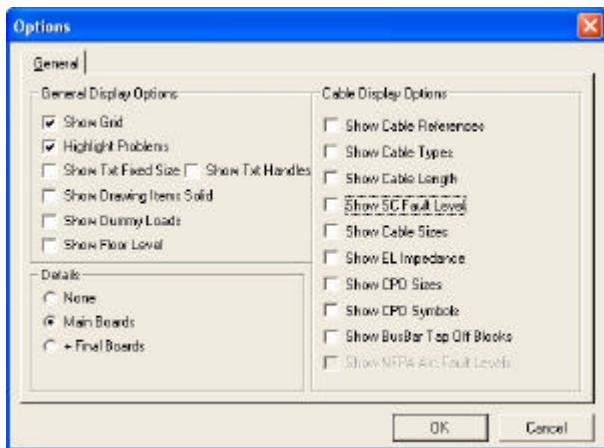

Once you select the 'Show SC Fault Level, you will now have the following additional new option 'Show NFPA Arc Fault Levels'.

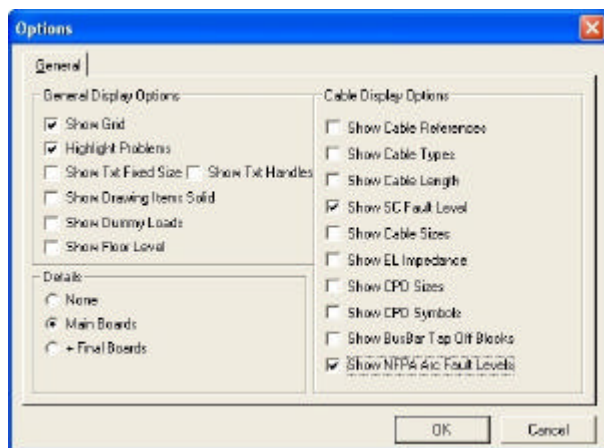

With this option selected when you next do a calculation for your Wiring project, you will be shown the following values:

Butter

53.00 kA
 AF: 25.9cal/cm² @460mm
 AFB(mm):1076
 SC Time: 0.13s

- 1). Three Phase Symmetrical Short Circuit Current.
- 2). Calculated Arc Flash Value (AF) in this case 25.9 Calories/Cm² at a typical working distance of 18"/460mm approx.
- 3). Arc Flash Boundary (AFB) Distance in this case (1076mm) this is the safe maximum approach limit (1.2 Cal/Cm²).

With this information you can then make an informed choice about the protection measure required for working in these areas. If the display option for 'Arc Flash' is currently active in your project, then when you next display a sub-main schedule you will be able to see a summary of the boundary and flash values on the last two columns of your 'sub main cable schedule' as shown below:

Display Schedule													
Display Type: <input type="text" value="Cables & Voldrops"/> <input type="checkbox"/> Vd%													
Length m	Conn. From	Conn. To	CPD Size	CPD Type	Amps	CableVD%	System VD%	Minimum Allowable	Zs	Temp Factor	Group Factor	It	
8.9	E52N/1/1B/1	E52N/1/1B/1/2L1	32A	B588 Fuse	3.0	0.0776	2.0799 1.84*	0.239	1.00	1.00	0.80	41	
9.2	E52H/1/1D/1	E52H/1/1D/1/3L1	32A	B588 Fuse	3.0	0.0802	2.0592 1.84*	0.25	1.00	1.00	0.80	41	
16.5	E52Q/1/1E/1	E52Q/1/1E/1/3L2	32A	B588 Fuse	4.0	0.1919	1.7506 1.84*	0.311	1.00	1.00	0.80	41	
0.1	Bus 48	E52P/1/1C	---	None	0.9	0.00	0.0 0.168	0.114	1.00	1.00	1.00	50	
0.1	E52H/1	Bus 34	---	None	194.8	0.0038	---	0.102	0.096	1.00	1.00	46	
0.1	Bus 34	Bus 36	---	None	189.8	0.0038	---	0.102	0.096	1.00	1.00	46	
0.1	Bus 34	E52H/1/1A	---	None	5.0	0.00	---	0.102	0.096	1.00	1.00	46	
0.1	Bus 36	E52H/1/1B	---	None	17.0	0.0001	---	0.048	0.096	1.00	1.00	46	
0.5	Bus 36	Bus 37	---	None	172.8	0.0036	---	0.102	0.096	1.00	1.00	46	
0.1	Bus 37	E52H/1/1C	---	None	0.1	0.00	---	0.048	0.096	1.00	1.00	46	
0.5	Bus 37	Bus 38	---	None	172.7	0.0036	---	0.102	0.096	1.00	1.00	46	
0.1	Bus 38	E52H/1/1D	---	None	4.9	0.00	---	0.102	0.096	1.00	1.00	46	
0.5	Bus 38	Bus 39	---	None	168.0	0.0035	---	0.102	0.096	1.00	1.00	46	

Calculation based on: SUPPLY

The NFPA 70E Standard suggests the following guidance: on personal protective equipment to be worn by operatives.

Category	Energy Level	PPE (Personal Protective Equipment)
0	<=2 cal/cm ²	Non melting flammable materials
1	4 cal/cm ²	Flame resistant shirt/trousers
2	8 cal/cm ²	Flame resistant shirt/trousers & cotton underwear
3	25 cal/cm ²	Two layers of FR clothing & cotton underwear
4	40 cal/cm ²	FR shirt, FR Trousers, Multi layer flash suit, cotton underwear

Lastly, you must remember when doing the analysis for multiple supplied systems that this can have a large impact on fault levels, particularly if there are bus ties or bus couplers in your distribution system. We advise calculating levels based on bus ties/couplers being closed, unless there are interlocks that prevent bus ties being closed and hence provide higher fault levels and exposure risks.

Quickplan Program

Changes have been made to allow the user to change the extents and border around an existing drawing file. If for example you want to amend the drawing and put further detail outside the original boundary set up you can do so by recalling the General Information dialog box from EDIT - GENERAL and increase the border area. For example, take the layout below:

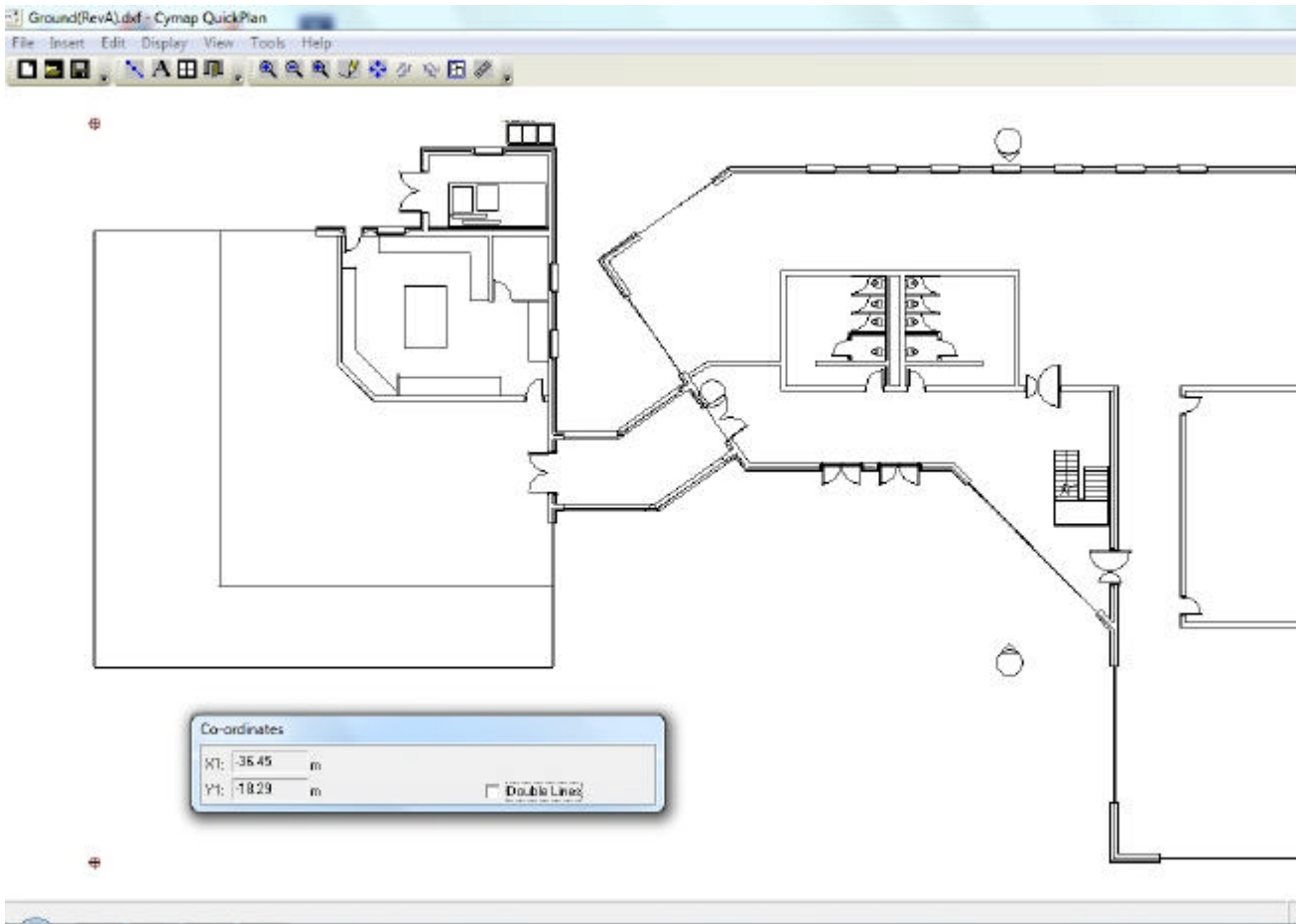

Go to Edit General and change the extents (as below):

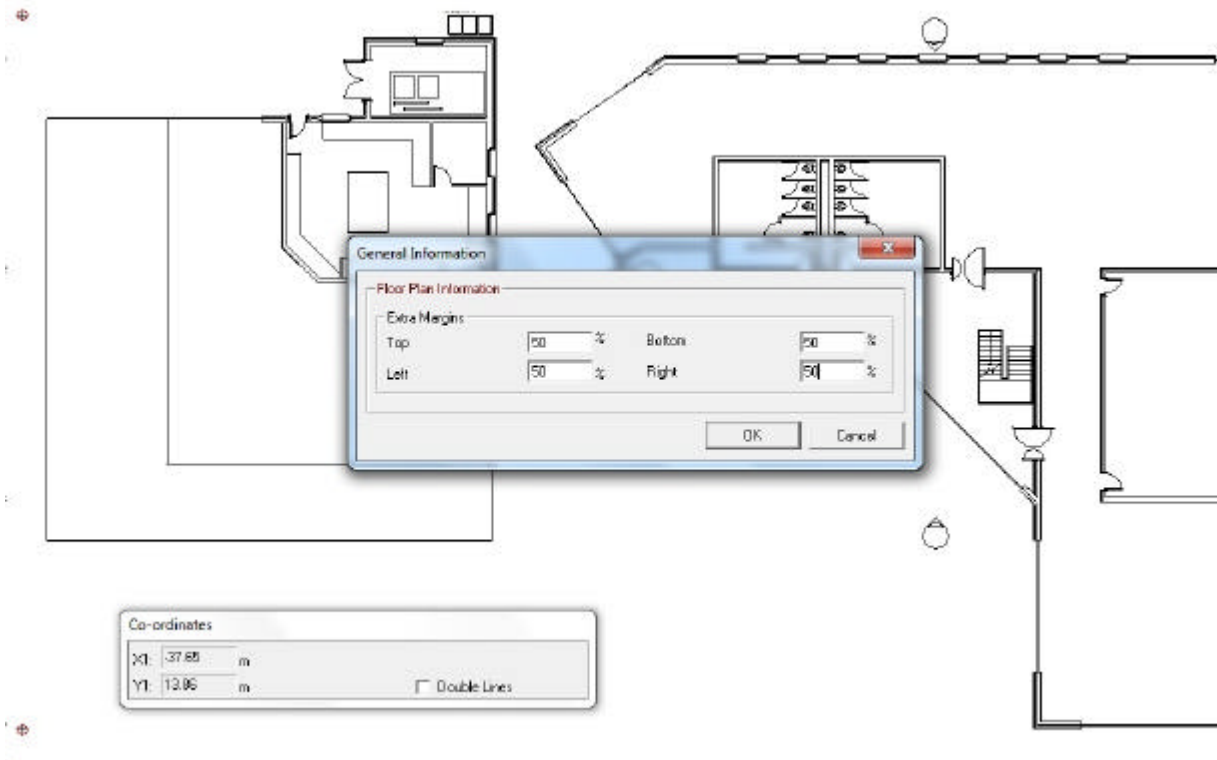

Your drawing will appear as below. You don't necessarily have to apply equal extents around the layout. The extents are shown by small points around the layout for guidance.

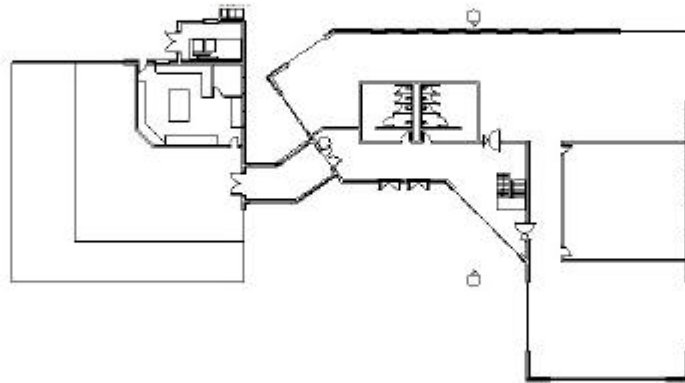

Co-ordinates

X1:	-12.79	m
Y1:	18.30	m

Double Lines

Building Program

Copy Rooms

You can now duplicate existing rooms defined on your layout. Simply select the room then right button mouse click and select "Copy Rooms" from the menu.

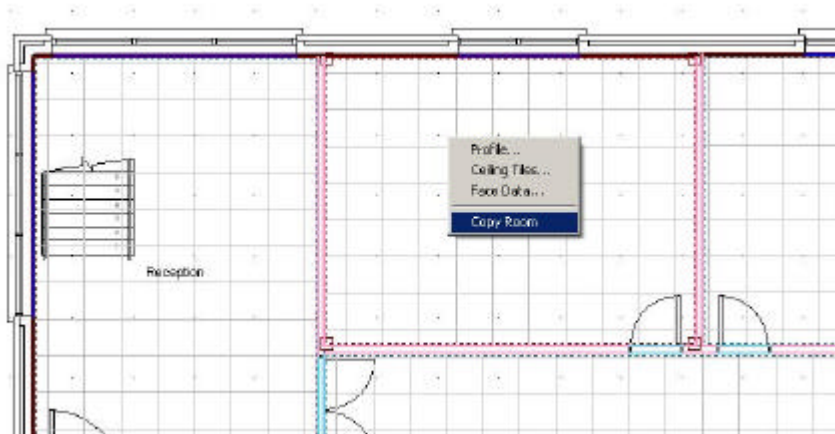

This will put a floating room representation on your mouse cursor. Line the room up with the underlying plan click LH button once and the room will be positioned. Another room will appear on the mouse so you can undertake multiple copies. Press ESC to cancel. If the room is a red colour this signifies the room cannot be placed due to:

- Overlapping an existing room
- Room being dropped outside the extents of the drawing boundary

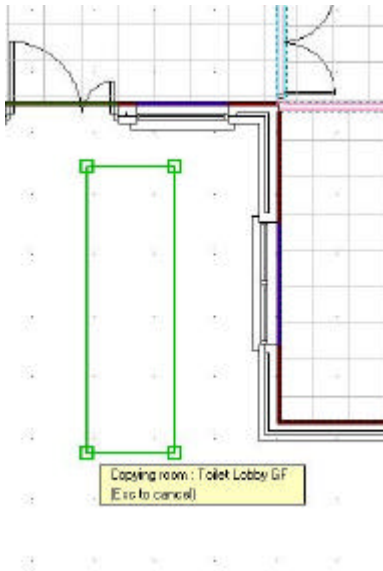

Moving Rooms

You can move rooms by selecting the room, then pressing the Ctrl key whilst dragging one of the grips (as you would with any other Windows application) and drag the room to the new position. On letting go of the Ctrl key this drops the room. Grabbing the grip first will only drag the grip and stretch the room.